



AIR PLATE P-15 (AP02-P15)

USER GUIDE

V1.1

Revision	Date	Revision Details	Revised By
1.1	26/01/26	Projector Models Removed	ST

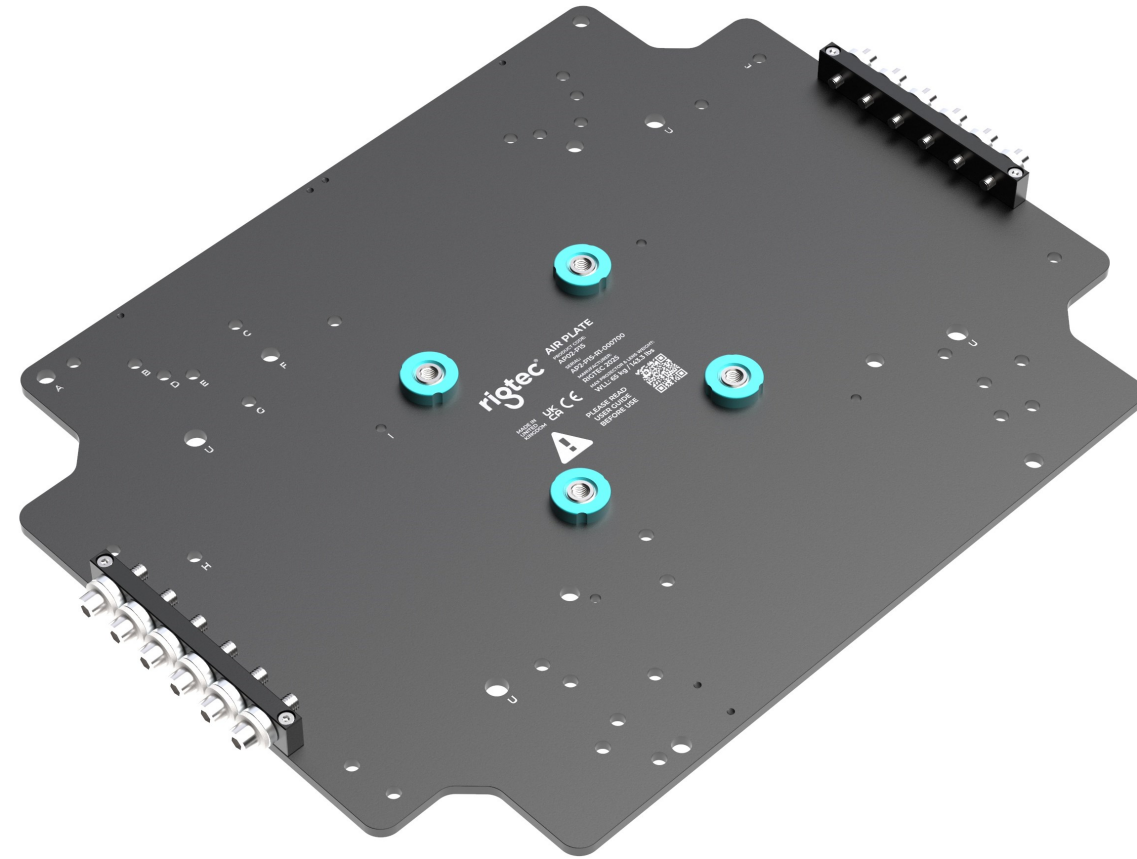



Thank you for purchasing a Rigtec Air Plate.

We hope you enjoy using the Air Plate as much as we've enjoyed designing and manufacturing it.

If you have any questions, suggestions or just want to say hello; please contact the team at hello@rigtec.com

Our user guides are regularly updated to include new projector models, so it is important to check that the R number on your Air Plate corresponds to the R number on the front cover of this user guide (Found in the bottom left corner)

The R number is within the serial number on the Air Plate, as highlighted here:



If your Air Plate has an older R number, please contact Rigtec for the correct version User Guide for your Air Plate.



CONTENTS

SAFETY INFORMATION	3
SAFETY INSPECTION	4
AIR PLATE PARTS	5
COMPATIBLE PROJECTORS	6
INSTALLATION ACCESSORIES	8
INSTALLING ON A PROJECTOR	16
HANGING ACCESSORIES	17
ATTACHING AN ATOM GRIP	18
MOUNTING ACCESSORY STORAGE BLOCKS	19
ACCESSORY ATTACHMENT BRACKET	20
SAFETY STEEL CABLES	21
SPECIFICATIONS	22
DIMENSIONS	23
CE DECLARATION OF CONFORMITY	24
UKCA DECLARATION OF CONFORMITY	25

SAFETY INFORMATION

These instructions should be handed over to the person carrying out the installation.

- Only a qualified, trained and competent technician should carry out installation work.
- The device should only be used with approved accessories and spares.
- Do not exceed the Working Load Limit (WWL) – when used with other accessories make sure that the Working Load Limit of any component is not exceeded.
- Care should be taken when lifting and moving – the combined weight of the device and any accessory should be within safe manual handling limits.
- Care should be taken when transporting that injury is not caused - make sure the device and any attached accessory is correctly secured.
- All equipment should be visually inspected before use and in the event of any damage, it must be immediately taken out of service and assessed by a competent person.
- Any suspended accessory must be independently secured with an approved safety wire/s. Local laws or regulations should be consulted regarding the additional safety of hanging equipment.

- When working at elevated heights or under a suspended load, make sure that all necessary precautions have been taken.
- Only install the approved projectors on to the Air Plate, as listed in the User Guide. Attempting to install projectors other than those listed in the User Guide may result in serious injury.
- Do not use the Air Plate outdoors. The Air Plate should not be installed where it can be exposed to wind or rain.
- Do not expose the Air Plate to moisture or excessive heat.
- Do not install the Air Plate on unstable surfaces.
- Do not hang the Air Plate from unstable, unsafe or inappropriate objects/structures. Ensure the structure can support the overall weight.
- Do not install an Air Plate whilst people are under the hanging area.
- Do not make adjustments to a hanging Air Plate or Atom Grip whilst people are under the hanging area.
- A Minimum of TWO people should be used to lift, carry and install the Air Plate with a projector installed.
- Thorough examination of lifting equipment must take place at least every 12 months by a qualified technician.
- No projectors other than those listed in this user guide should be mounted to the Air Plate. Failure to comply with this could lead to serious failure of the product.

In addition to these scheduled examinations, equipment will require a thorough examination following:

- Any accident or dangerous occurrence.
- Any significant change in conditions of use.
- Any long periods of inaction.
- Each time the equipment is used.



SAFETY INSPECTION

The Air Plate should always be inspected to check for defects. It is important to inspect the Air Plate for damaged, broken, misshapen or missing parts. If any of these issues are found, the product must not be used.

Along with an overall visual check covering the issues above, the following specific parts should be checked before the product is used:

1. Ensure the four M8 Rivet Nuts are not loose or damaged.

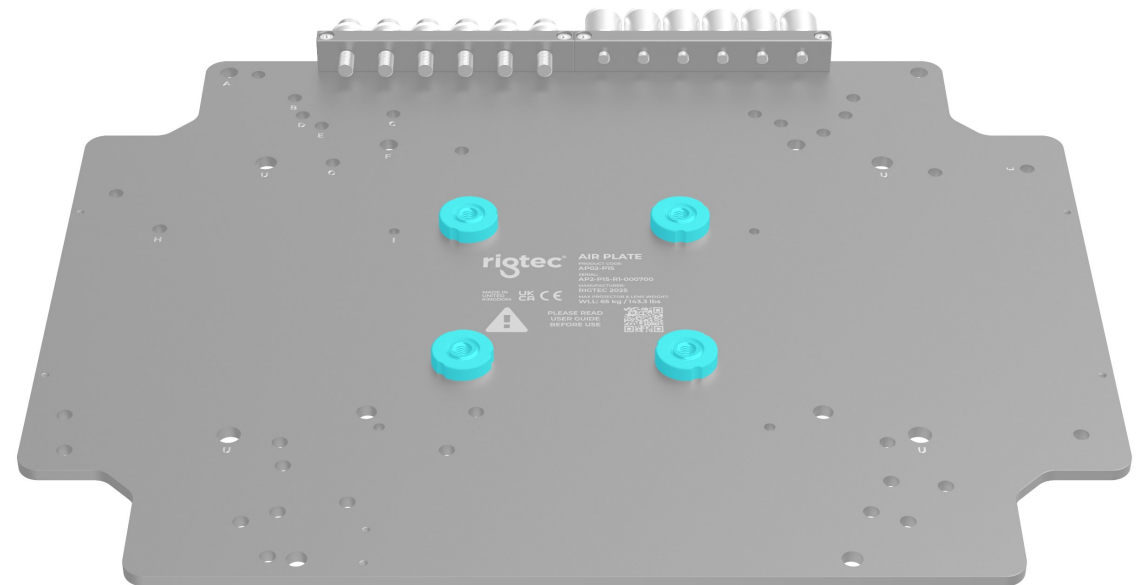



PART NAMES

Use this page as a reference of the various part names used throughout this User Guide.

1. Atom Grip Mounting Thread
2. Mounting Accessory Storage Block (Optional)
3. Hole Set Indicators (Labelled A-J)
4. Unistrut Adapter Attachment Hole (Labelled U)
5. Safety Cable Eye Bolt (M8)
6. Accessory Attachment Bracket (Optional)

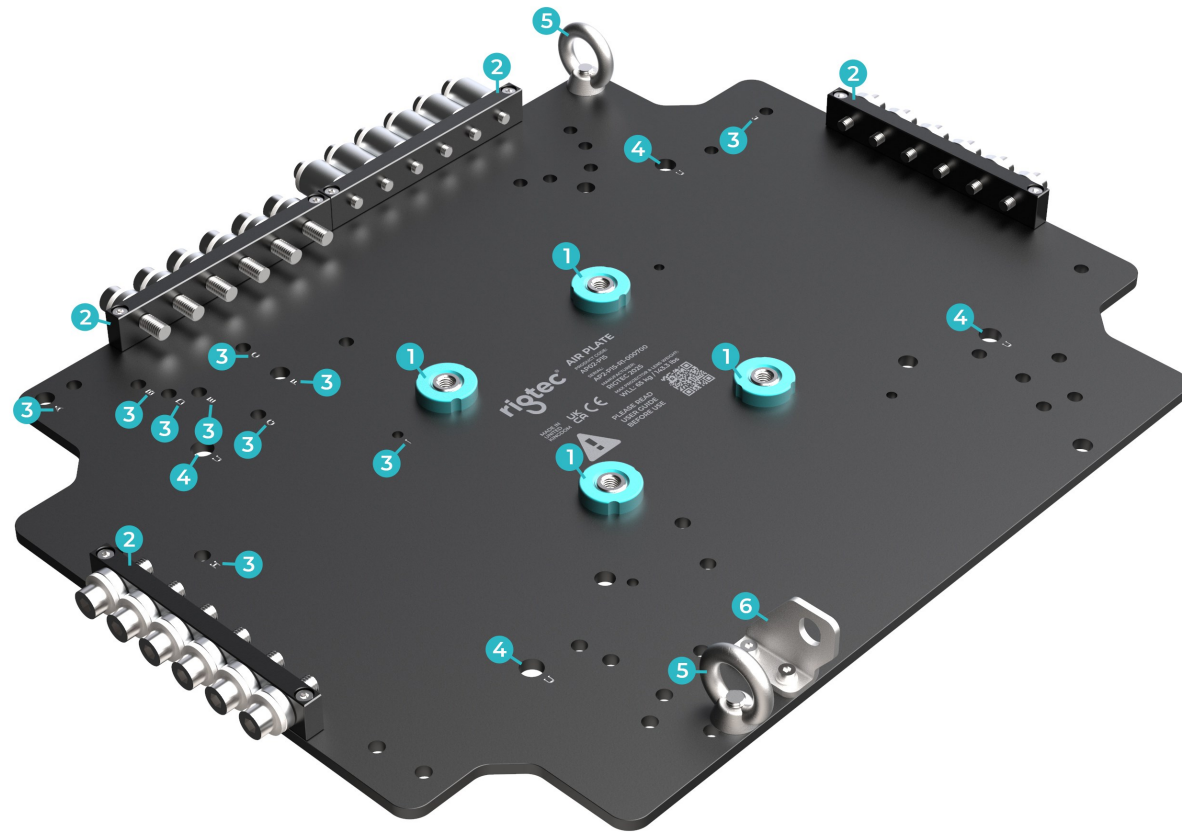



COMPATIBLE PROJECTORS

The Air Plate P-15 has ten hole sets. One hole from each set is labelled with a letter to aid the installation process. When installing a projector, begin with the labelled hole which will then line up the other holes in the associated hole set. Please see the compatibility table on the next page for a full list of compatible projectors and an itemisation of each hole set, and the installation accessory table to find out what accessories are required to install your projector.

Do not mount any projector that is not listed in this guide to the Air Plate. This product is engineered and tested only for the approved models, and using unlisted projectors can create unsafe loads that may result in structural failure, equipment damage, or risk of injury.





COMPATIBLE PROJECTORS

Hole Set A	Hole Set B	Hole Set C	Hole Set D	Hole Set E	Hole Set F	Hole Set G	Hole Set H	Hole Set I	Hole Set J
Barco: <ul style="list-style-type: none"> G100 W16 G100 W19 G100 W22 G100 W25 Optoma: <ul style="list-style-type: none"> ZU1700 ZU1900 ZU2200 Christie: <ul style="list-style-type: none"> 4K22-HS 4K13-HS D13WU2-HS DWU15-HS DWU19-HS DWU23-HS 4K10-HS 4K7-HS DWU2400-JS DWU1800-JS 4K2100-JS 4K1600-JS 	Barco: <ul style="list-style-type: none"> G60-W7 G60-W8 G60-W10 G62-W9 G62-W11 G62-W14 Optoma: <ul style="list-style-type: none"> ZU660e ZU750 ZU850 ZU860 ZU1050 ZU1100 ZU1300 	Epson: <ul style="list-style-type: none"> EB-PU1006 EB-PU1007 EB-PU1008 EB-PQ2008 EB-PQ2010B EB-PU2010 EB-PU2113 EB-PU2116 EB-PU2120 EB-PU2213 EB-PU2216 EB-PU2220 EB-PQ2213 EB-PQ2216 EB-PQ2220B 	Christie: <ul style="list-style-type: none"> DWU880-GS DWU1100-GS DWU1400-GS DHD700-GS DWU700-GS DHD850-GS DWU850-GS DHD1075-GS DWU1075-GS 	Panasonic: <ul style="list-style-type: none"> PT-RW620 PT-RW630 PT-RZ660 PT-RZ670 PT-RW730 PT-RZ770 PT-RZ870 PT-RW930 PT-RZ970 PT-RX110 PT-RZ120 PT-RCQ10 PT-RCQ80 PT-RZ690 PT-RZ790 PT-RZ890 PT-RZ990 PT-RQ6 PT-RQ7 PT-RZ6 PT-RZ7 	Barco: <ul style="list-style-type: none"> I600-4K8 I600-4K10 I600-4K15 	Christie: <ul style="list-style-type: none"> DWU630-GS DWU635-GS 	Panasonic: <ul style="list-style-type: none"> PT-MZ680 PT-MZ780 PT-MZ880 PT-MZ682 PT-MZ782 PT-MZ882 PT-MZ10KL PT-MZ11KL PT-MZ13KL PT-MZ14KL PT-MZ16KL PT-MZ17KL PT-MZ20KL 	Optoma: <ul style="list-style-type: none"> ZU920T ZU920TST ZU820T ZU820TST ZK810T ZK810TST Barco: <ul style="list-style-type: none"> G50-W6 G50-W7 G50-W8 Christie: <ul style="list-style-type: none"> DWU760-iS DWU860-iS DWU960-iS DWU960ST-iS 4K860-iS 	Panasonic: <ul style="list-style-type: none"> PT-RZ14K PT-RZ17K PT-RQ18K PT-RZ24K PT-RQ25K



INSTALLATION ACCESSORIES

Rigtec Air Plates are provided with the necessary accessories to mount your projector onto the plate. Bolts, washers and spacers will be required for all projectors, using the incorrect size could lead to damage to the projector or serious failure of the Air Plate.

To identify the correct mounting accessories, please see the chart on the back of the Projector Mount Kit inside the Air Plate packaging. The chart can be used to measure the length of bolts and spacers, and the accessory diagrams can be used to identify the correct diameter of bolts, washers and spacers.

Please consult the tables on pages 10, 11, 12, 13, 14 and 15 to find the correct bolts, washers and spacers to use with your projector. The number in brackets following the projector model shows the quantity of bolts, spacers and washers required for that model, this quantity must be used. Failure to use the full amount of spacers, bolts and washers could lead to serious failure of the Air Plate.

Washers

Rigtec provide two options of washers, these can be selected depending on the application of the Air Plate:

Anti Vibration Washers - Ideal for permanent installations.

Flat Washers - Ideal when projector will be regularly removed.

Anti Vibration Washers may damage the paint finish of the Air Plate with excessive installation and removal. Using the flat washers will help protect the paint finish.

Do not install both types of washers together.

Only one type of washer should be installed at once.



INSTALLATION ACCESSORIES

Spacers

Spacers must be used to mount all projectors to the Air Plate. With certain projectors it is necessary to stack two spacers, to create a larger spacer, these projectors are marked with an * in the Installation Accessories Tables but can also be found here:

- **Barco I600 & G100 Series**
Stack 5mm and 2mm Spacers to create a 7mm Spacer
- **Barco G62 Series**
Stack 20mm and 10mm Spacers to create a 30mm Spacers
- **Christie GS Series**
Stack 20mm and 10mm Spacers to create a 30mm Spacer
- **Christie DWU630-GS & DWU635-GS**
Stack 10mm and 5mm Spacers to create a 15mm Spacer
- **Optoma ZU660e, ZU750, ZU850, ZU860, ZU1050, ZU110, ZU1300**
Stack 20mm and 10mm Spacers to create a 30mm Spacer

Be aware that the Projector Mounting Kit contains 20mm and 22mm spacers, please measure the spacers accurately to ensure the correct size is used when mounting your projector.

Third Party Accessories

Where third party accessories are to be used with the Air Plate, such as a the Dynamic Projection Mirror Head, please contact the team at Rigtec to discuss. Alternative bolts and spacers will be required to accommodate the accessory.





The full amount of spacers, bolts & washers MUST be used.
 Please Torque bolts to 4±0.5 Nm (Or as recommended by the Projector Manufacturer in the Projector User guide)
 Only use supplied bolts to connect Air Plate and Projector.

Projector Model	M8 40mm Bolt	M8 30mm Bolt	M8 25mm Bolt	M6 45mm Bolt	M6 40mm Bolt	M6 30mm Bolt	M6 25mm Bolt	M6 22mm Bolt	M4 30mm Bolt	M4 25mm Bolt	M4 22mm Bolt	22mm Spacer*	20mm Spacer*	10mm Spacer	5mm Spacer	2mm Spacer	M4 10mm Spacer	M8 Washer	M6 Washer	M4 Washer
Barco G100 W16 [4] **			◆												◆	◆		◆		
Barco G100 W19 [4] **			◆												◆	◆		◆		
Barco G100 W22 [4] **			◆												◆	◆		◆		
Barco G100 W25 [4] **			◆												◆	◆		◆		
Barco G60-W7 [4] ***				◆									◆	◆					◆	
Barco G60-W8 [4] ***				◆									◆	◆					◆	
Barco G60-W10 [4] ***				◆									◆	◆					◆	
Barco G62-W9 [4] ***				◆									◆	◆					◆	
Barco G62-W11 [4] ***				◆									◆	◆					◆	
Barco G62-W14 [4] ***				◆									◆	◆					◆	
Barco I600-4K8 [4] **			◆												◆	◆		◆		
Barco I600-4K10 [4] **			◆												◆	◆		◆		
Barco I600-4K15 [4] **			◆												◆	◆		◆		
Barco G50-W6 [4]										◆							◆			◆
Barco G50-W7 [4]										◆							◆			◆
Barco G50-W8 [4]										◆							◆			◆
Panasonic PT-RW620 [5]								◆							◆				◆	
Panasonic PT-RW630 [5]								◆							◆				◆	
Panasonic PT-RZ660 [5]								◆							◆				◆	
Panasonic PT-RZ670 [5]								◆							◆				◆	
Panasonic PT-RW730 [5]								◆							◆				◆	
Panasonic PT-RZ770 [5]								◆							◆				◆	

* Be aware that the Projector Mounting Kit contains 20mm and 22mm spacers, please measure the spacers accurately to ensure the correct size is used when mounting your projector.

** Barco I600 & G100 Series requires 5mm and 2mm Spacers to be stacked, to create a 7mm Spacer

*** Barco G62 Series requires 20mm and 10mm Spacers to be stacked, to create a 30mm Spacer

I +44 (0)1926 290 418 E / hello@rigtec.com W / www.rigtec.com



The full amount of spacers, bolts & washers MUST be used.
 Please Torque bolts to 4±0.5 Nm (Or as recommended by the Projector Manufacturer in the Projector User guide)
 Only use supplied bolts to connect Air Plate and Projector.

Projector	M8 40mm Bolt	M8 30mm Bolt	M8 25mm Bolt	M6 45mm Bolt	M6 40mm Bolt	M6 30mm Bolt	M6 25mm Bolt	M6 22mm Bolt	M4 30mm Bolt	M4 25mm Bolt	M4 22mm Bolt	22mm Spacer*	20mm Spacer*	10mm Spacer	5mm Spacer	2mm Spacer	M4 10mm Spacer	M8 Washer	M6 Washer	M4 Washer
Panasonic PT-RZ870 [5]								◆							◆				◆	
Panasonic PT-RW930 [5]								◆							◆				◆	
Panasonic PT-RZ970 [5]								◆							◆				◆	
Panasonic PT-RX110 [5]								◆							◆				◆	
Panasonic PT-RZ120 [5]								◆							◆				◆	
Panasonic PT-RCQ10 [5]								◆							◆				◆	
Panasonic PT-RCQ80 [5]								◆							◆				◆	
Panasonic PT-RZ690 [5]								◆							◆				◆	
Panasonic PT-RZ790 [5]								◆							◆				◆	
Panasonic PT-RZ890 [5]								◆							◆				◆	
Panasonic PT-RZ990 [5]								◆							◆				◆	
Panasonic PT-RQ6 [5]								◆							◆				◆	
Panasonic PT-RQ7 [5]								◆							◆				◆	
Panasonic PT-RZ6 [5]								◆							◆				◆	
Panasonic PT-RZ7 [5]								◆							◆				◆	
Panasonic PT-REQ10 [5]								◆							◆				◆	
Panasonic PT-REQ12 [5]								◆							◆				◆	
Panasonic PT-REQ15 [5]								◆							◆				◆	
Panasonic PT-REQ80 [5]								◆							◆				◆	
Panasonic PT-REZ10 [5]								◆							◆				◆	
Panasonic PT-REZ12 [5]								◆							◆				◆	
Panasonic PT-REZ15 [5]								◆							◆				◆	
Panasonic PT-REZ80 [5]								◆							◆				◆	

* Be aware that the Projector Mounting Kit contains 20mm and 22mm spacers, please measure the spacers accurately to ensure the correct size is used when mounting your projector.

/ +44 (0)1926 290 418 E / hello@rigtec.com W / www.rigtec.com

The full amount of spacers, bolts & washers MUST be used.
 Please Torque bolts to 4±0.5 Nm (Or as recommended by the Projector Manufacturer in the Projector User guide)
 Only use supplied bolts to connect Air Plate and Projector.

Projector	M8 40mm Bolt	M8 30mm Bolt	M8 25mm Bolt	M6 45mm Bolt	M6 40mm Bolt	M6 30mm Bolt	M6 25mm Bolt	M6 22mm Bolt	M4 30mm Bolt	M4 25mm Bolt	M4 22mm Bolt	22mm Spacer*	20mm Spacer*	10mm Spacer	5mm Spacer	2mm Spacer	M4 10mm Spacer	M8 Washer	M6 Washer	M4 Washer
Panasonic PT-MZ680 [5]					◆							◆							◆	
Panasonic PT-MZ780 [5]					◆							◆							◆	
Panasonic PT-MZ880 [5]					◆							◆							◆	
Panasonic PT-MZ682 [5]					◆							◆							◆	
Panasonic PT-MZ782 [5]					◆							◆							◆	
Panasonic PT-MZ882 [5]					◆							◆							◆	
Panasonic PT-MZ10KL [5]								◆							◆				◆	
Panasonic PT-MZ11KL [5]								◆							◆				◆	
Panasonic PT-MZ13KL [5]								◆							◆				◆	
Panasonic PT-MZ14KL [5]								◆							◆				◆	
Panasonic PT-MZ16KL [5]								◆							◆				◆	
Panasonic PT-MZ17KL [5]								◆							◆				◆	
Panasonic PT-MZ20KL [5]								◆							◆				◆	
Panasonic PT-RZ14K [6]							◆								◆				◆	
Panasonic PT-RZ17K [6]							◆								◆				◆	
Panasonic PT-RQ18K [6]							◆								◆				◆	
Panasonic PT-RZ24K [6]							◆								◆				◆	
Panasonic PT-RQ25K [6]							◆								◆				◆	
Christie 4K22-HS [4]	◆													◆				◆		
Christie 4K13-HS [4]	◆													◆				◆		
Christie D13WU2-HS [4]	◆													◆				◆		
Christie DWU15-HS [4]	◆													◆				◆		

* Be aware that the Projector Mounting Kit contains 20mm and 22mm spacers, please measure the spacers accurately to ensure the correct size is used when mounting your projector.



The full amount of spacers, bolts & washers MUST be used.
 Please Torque bolts to 4±0.5 Nm (Or as recommended by the Projector Manufacturer in the Projector User guide)
 Only use supplied bolts to connect Air Plate and Projector.

Projector	M8 40mm Bolt	M8 30mm Bolt	M8 25mm Bolt	M6 45mm Bolt	M6 40mm Bolt	M6 30mm Bolt	M6 25mm Bolt	M6 22mm Bolt	M4 30mm Bolt	M4 25mm Bolt	M4 22mm Bolt	22mm Spacer*	20mm Spacer*	10mm Spacer	5mm Spacer	2mm Spacer	M4 10mm Spacer	M8 Washer	M6 Washer	M4 Washer
Christie DWU19-HS [4]	◆													◆				◆		
Christie DWU23-HS [4]	◆													◆				◆		
Christie 4K10 [4]		◆												◆				◆		
Christie 4K7 [4]		◆												◆				◆		
Christie DWU2400-JS [4]			◆												◆			◆		
Christie DWU1800-JS [4]			◆												◆			◆		
Christie 4K2100-JS [4]			◆												◆			◆		
Christie 4K1600-JS [4]			◆												◆			◆		
Christie DWU880-GS [4] **				◆									◆	◆						◆
Christie DWU1100-GS [4] **				◆									◆	◆						◆
Christie DWU1400-GS [4] **				◆									◆	◆						◆
Christie DHD700-GS [4] **				◆									◆	◆						◆
Christie DWU700-GS [4] **				◆									◆	◆						◆
Christie DHD850-GS [4] **				◆									◆	◆						◆
Christie DWU850-GS [4] **				◆									◆	◆						◆
Christie DHD1075-GS [4] **				◆									◆	◆						◆
Christie DWU1075-GS [4] **				◆									◆	◆						◆
Christie DWU630-GS [4] ***						◆								◆	◆					◆
Christie DWU760-iS [4]											◆			◆						◆
Christie DWU860-iS [4]											◆			◆						◆
Christie DWU960-iS [4]											◆			◆						◆
Christie DWU960ST-iS [4]											◆			◆						◆

* Be aware that the Projector Mounting Kit contains 20mm and 22mm spacers, please measure the spacers accurately to ensure the correct size is used when mounting your projector.

** Christie GS Series requires 20mm and 10mm Spacers to be stacked, to create a 30mm Spacer

*** Christie DWU630-GS requires 10mm and 5mm Spacers to be stacked, to create a 15mm Spacer

I +44 (0)1926 290 418 E / hello@rigtec.com W / www.rigtec.com

The full amount of spacers, bolts & washers MUST be used.
 Please Torque bolts to 4±0.5 Nm (Or as recommended by the Projector Manufacturer in the Projector User guide)
 Only use supplied bolts to connect Air Plate and Projector.

Projector	M8 40mm Bolt	M8 30mm Bolt	M8 25mm Bolt	M6 45mm Bolt	M6 40mm Bolt	M6 30mm Bolt	M6 25mm Bolt	M6 22mm Bolt	M4 30mm Bolt	M4 25mm Bolt	M4 22mm Bolt	22mm Spacer*	20mm Spacer*	10mm Spacer	5mm Spacer	2mm Spacer	M4 10mm Spacer	M8 Washer	M6 Washer	M4 Washer
Christie DWU635-GS [4] **						◆									◆	◆			◆	
Christie 4K860-iS [4]											◆				◆					◆
Optoma ZU1700 [4]		◆													◆			◆		
Optoma ZU1900 [4]		◆													◆			◆		
Optoma ZU2200 [4]		◆													◆			◆		
Optoma ZU660e [4] ***				◆											◆	◆			◆	
Optoma ZU750 [4] ***				◆											◆	◆			◆	
Optoma ZU850 [4] ***				◆											◆	◆			◆	
Optoma ZU860 [4] ***				◆											◆	◆			◆	
Optoma ZU1050 [4] ***				◆											◆	◆			◆	
Optoma ZU1100 [4] ***				◆											◆	◆			◆	
Optoma ZU1300 [4] ***				◆											◆	◆			◆	
Optoma ZU920T [4]										◆							◆			◆
Optoma ZU920TST [4]										◆							◆			◆
Optoma ZU820T [4]										◆							◆			◆
Optoma ZU820TST [4]										◆							◆			◆
Optoma ZU810T [4]										◆							◆			◆
Optoma ZU810TST [4]										◆							◆			◆
Epson EB-PU1006 [5]							◆								◆				◆	
Epson EB-PU1007 [5]							◆								◆				◆	
Epson EB-PU1008 [5]							◆								◆				◆	
Epson EB-PQ2008 [5]							◆								◆				◆	

* Be aware that the Projector Mounting Kit contains 20mm and 22mm spacers, please measure the spacers accurately to ensure the correct size is used when mounting your projector.

** Christie DWU635-GS requires 10mm and 5mm Spacers to be stacked, to create a 15mm Spacer

*** Optoma ZU660e, ZU750, ZU850, ZU860, ZU1050, ZU110, ZU1300 require 20mm and 10mm Spacers to be stacked, to create a 30mm Spacer

The full amount of spacers, bolts & washers MUST be used.
 Please Torque bolts to 4±0.5 Nm (Or as recommended by the Projector Manufacturer in the Projector User guide)
 Only use supplied bolts to connect Air Plate and Projector.

Projector	M8 40mm Bolt	M8 30mm Bolt	M8 25mm Bolt	M6 45mm Bolt	M6 40mm Bolt	M6 30mm Bolt	M6 25mm Bolt	M6 22mm Bolt	M4 30mm Bolt	M4 25mm Bolt	M4 22mm Bolt	22mm Spacer*	20mm Spacer*	10mm Spacer	5mm Spacer	2mm Spacer	M4 10mm Spacer	M8 Washer	M6 Washer	M4 Washer
Epson EB-PQ2010B [5]							◆								◆				◆	
Epson EB-PU2010 [5]							◆								◆				◆	
Epson EB-PU2113 [5]							◆								◆				◆	
Epson EB-PU2116 [5]							◆								◆				◆	
Epson EB-PU2120 [5]							◆								◆				◆	
Epson EB-PU2213 [5]							◆								◆				◆	
Epson EB-PU2216 [5]							◆								◆				◆	
Epson EB-PU2220 [5]							◆								◆				◆	
Epson EB-PQ2213 [5]							◆								◆				◆	
Epson EB-PQ2216 [5]							◆								◆				◆	
Epson EB-PQ2220B [5]							◆								◆				◆	

* Be aware that the Projector Mounting Kit contains 20mm and 22mm spacers, please measure the spacers accurately to ensure the correct size is used when mounting your projector.



INSTALLING ON A PROJECTOR

Required Tools:

- 3mm Hex Key (For M4 Bolts)
- 5mm Hex Key (For M6 Bolts)
- 6mm Hex Key (For M8 Bolts)

See 'Installation Accessories' (page 8) for required accessories.

1. Turn the projector upside down and place onto a stable flat surface.
2. Place the provided spacers over the mounting points (threaded holes) of the projector.
3. Carefully lower the Air Plate over the projector. Carefully line the projector threaded holes up with the associated hole set in the Air Plate.
4. Using the provided accessories, secure the recommended number of bolts (Please consult the projector manufacturer's User Guide) through the provided washers (choose one option, see page 8), then through the Air Plate holes, then through the provided spacers and into the projector's threaded holes. Anti Vibration Washers must be orientated with convex surface against the bolt head and concave surface against the projector plate to help reduce vibrations. Use a Hex Key to tighten the bolts.

Do not install both types of washers together.

Only one type of washer should be installed at once. (See page 8)

Please torque bolts to 4 ± 0.5 Nm (or as recommended by the projector manufacturer in the projector user guide)

Only use supplied bolts to connect Air Plate and Projector.

I / +44 (0)1926 290 418 E / hello@rigtec.com W / www.rigtec.com

1



2

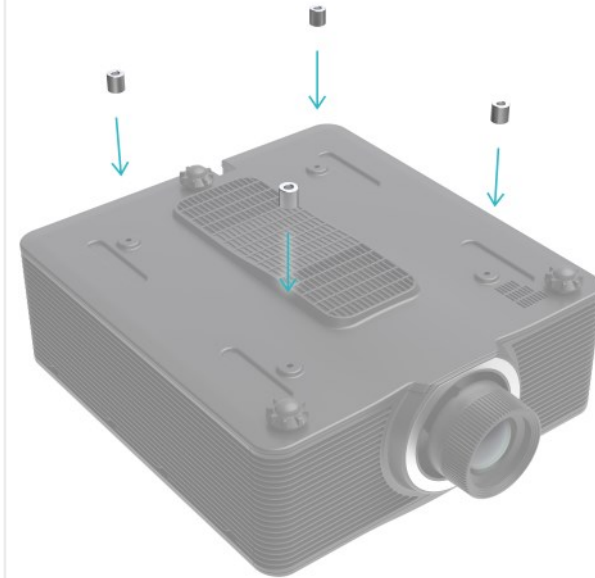

3

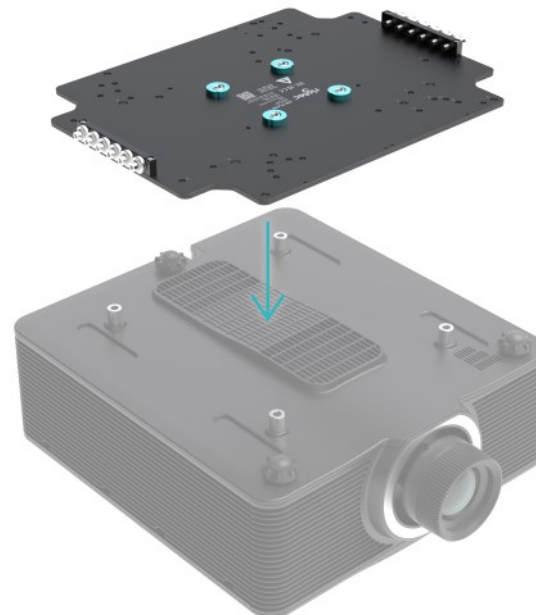

4

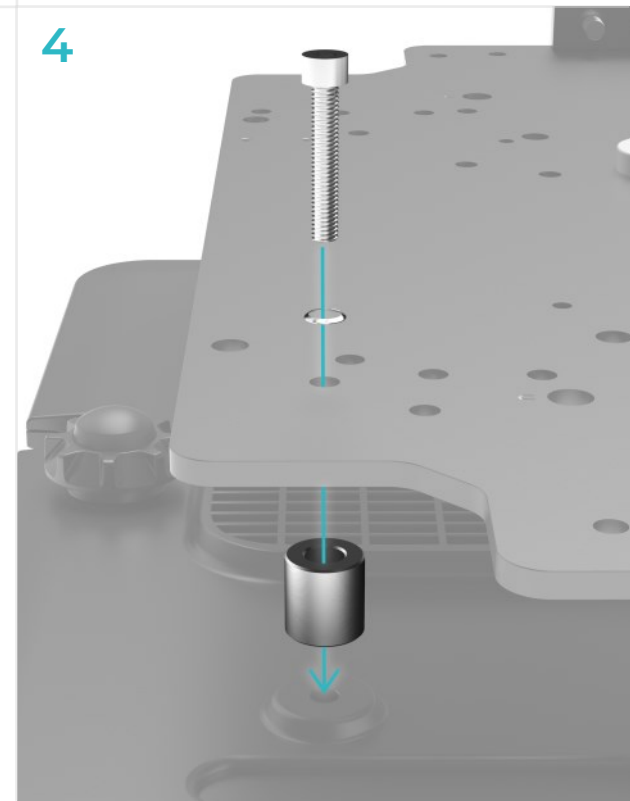



HANGING ACCESSORIES

There are several accessories to suspend an Air Plate, please see below for a list of those accessories and see the next page for instructions on how to safely suspend the Rigtec Air Plate.

Atom Grip (AG02-A): 245kg Single Point Trigger Clamp

Atom Grip Duo (AG02-D): 295kg Twin Point Quick Trigger Clamps

Atom Grip HD (AG02-H): 370kg Single Point Half Coupler

Unistrut Adapter (US-01): 60kg Per Adapter (240kg for four adapters)





ATTACHING AN ATOM GRIP

To attach an Atom Grip to the Air Plate please follow these instructions:

Required Tools:

- 6mm Hex Key (Allen Key)

1. Place the Atom Grip on to the Atom Grip Attachment Plate. Line the M8 bolts up with the M8 Rivet Nuts.
2. To help prevent damage to the M8 Rivet Nuts, it is good practice to initially attach the bolts by hand. Attach each bolt loosely, gradually tighten evenly.
3. Once all bolts are located in the threads and loosely attached use a 6mm Hex Key to tighten, tighten all four bolts evenly.
4. Ensure all four M8 bolts are **torqued to 6 ± 0.5 Nm (M8)**.

Any suspended accessory must be independently secured with an approved safety wire/s. Local laws or regulations should be consulted regarding the additional safety of hanging equipment

/ +44 (0)1926 290 418 E / hello@rigtec.com W / www.rigtec.com





MOUNTING ACCESSORY STORAGE BLOCKS

The optional Mounting Accessory Storage Blocks are used to store the Bolts, Spacers and Washers used to mount a projector to the plate. These are designed for when the Air Plate is a rental accessory to several projectors, allowing the user to have the Mounting Accessories available at all times.

Required Tools:

- 3mm Hex Key

1. The holes to mount the Storage Blocks are highlighted.
2. Using a 3mm Hex Key and the provided bolts attach the Storage Block to the Air Plate using any of the previously highlighted locations.
3. In total four Storage Blocks can be attached to the Air Plate.

/ +44 (0)1926 290 418 E / hello@rigtec.com W / www.rigtec.com

1

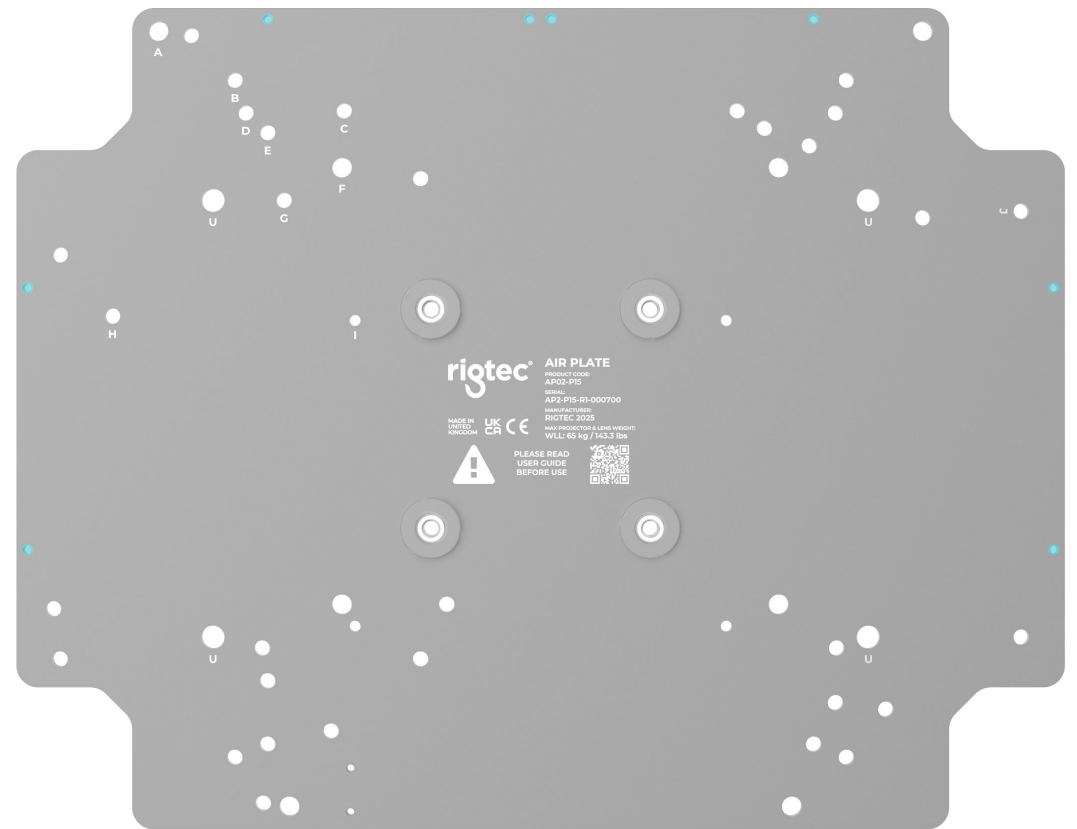

2

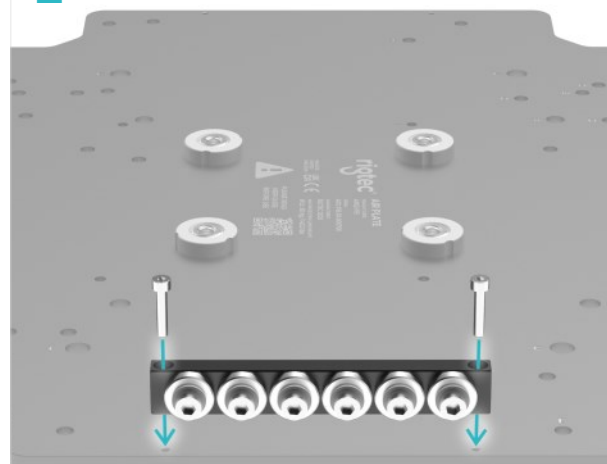

3





ACCESSORY ATTACHMENT BRACKET

The optional Accessory Attachment Bracket allows third party accessories, such as Theatrixx Xvision Converters, to be mounted to the Air Plate.

Required Tools:

- 3mm Hex Key
- 7mm Spanner / Wrench

1. The holes to mount the Bracket are highlighted.
2. Using the provided nuts and bolts, attach the Bracket to the Air Plate using the previously highlighted locations. The Bracket holes are threaded, so using the provided nuts is optional, but recommended on plates that are being permanently installed.
3. Always ensure the accessory and Accessory Attachment Bracket are correctly attached and tightened using a 3mm Hex Key and 7mm Spanner / Wrench before suspending the Air Plate.

/ +44 (0)1926 290 418 E / hello@rigtec.com W / www.rigtec.com

1

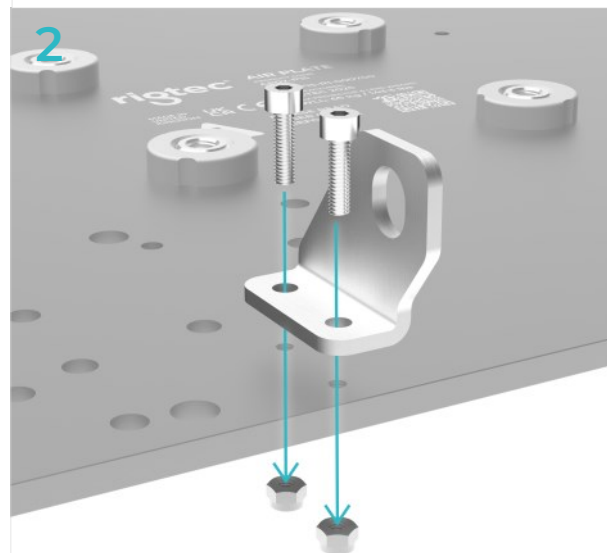
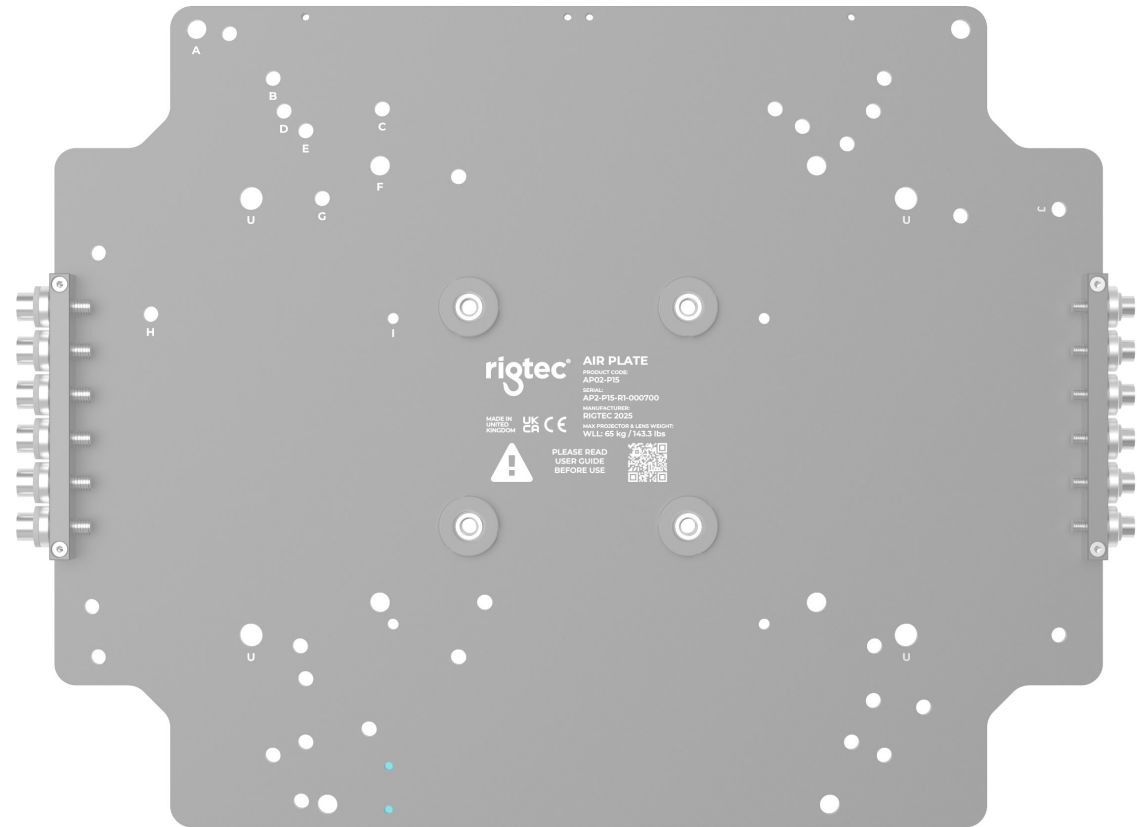



SAFETY STEEL CABLES

Required Tools:

- 5mm Hex Key

The installer bears the responsibility to ensure the Air Plate is suspended in a safe and secure fashion. Safety Steel Cables must be applied to suspended Air Plates according to local regulations and standards. For more information on safely suspending equipment please consult local laws and regulations.

The installer must ensure safety cables are the correct length, format and strength - No drop distance is allowed or must be limited as much as possible.

The Safety Cable Eye Bolts must be installed as shown in diagram 1. They can be installed through any M8 hole on the Air Plate, using the provided bolt and anti-vibration washer. Use a 5mm Hex Key to tighten the Eye Bolts.

To safely suspend the Air Plate, ensure that the safety steel cables are looped around the suspending truss and through the Safety Cable Eye Bolts on the Air Plate. Please use diagram 2 as guidance.

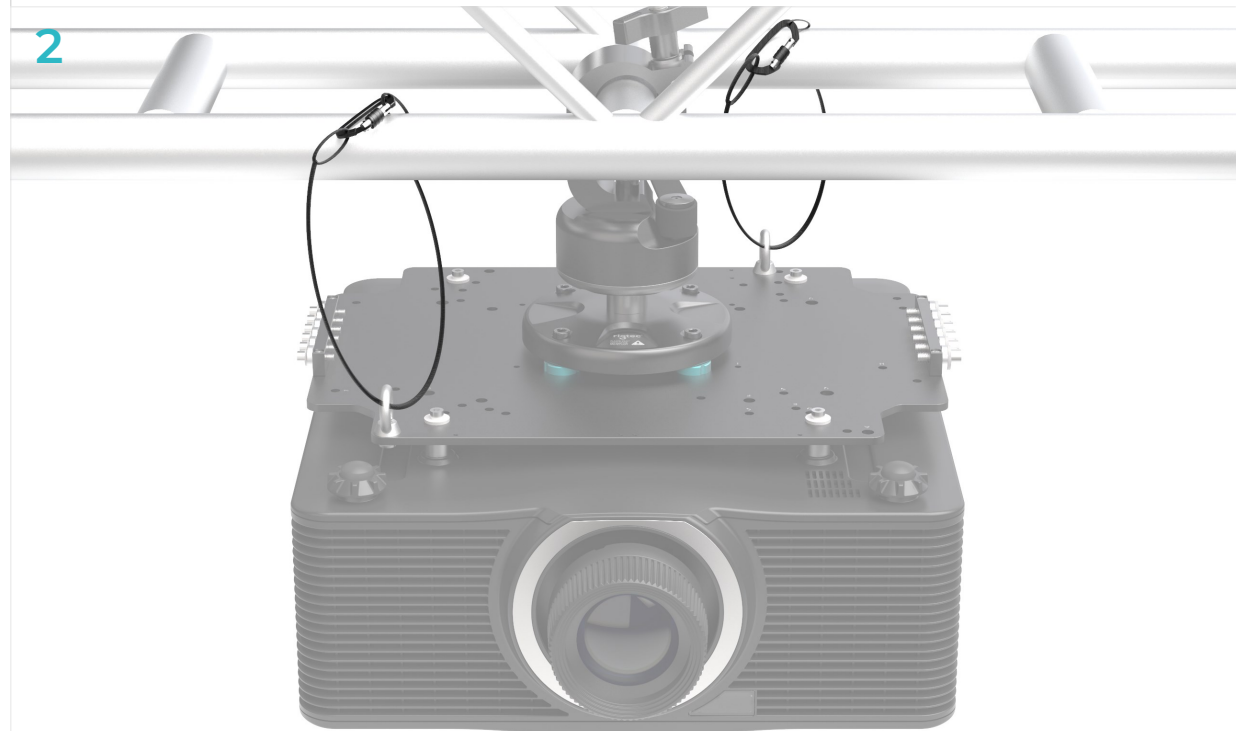
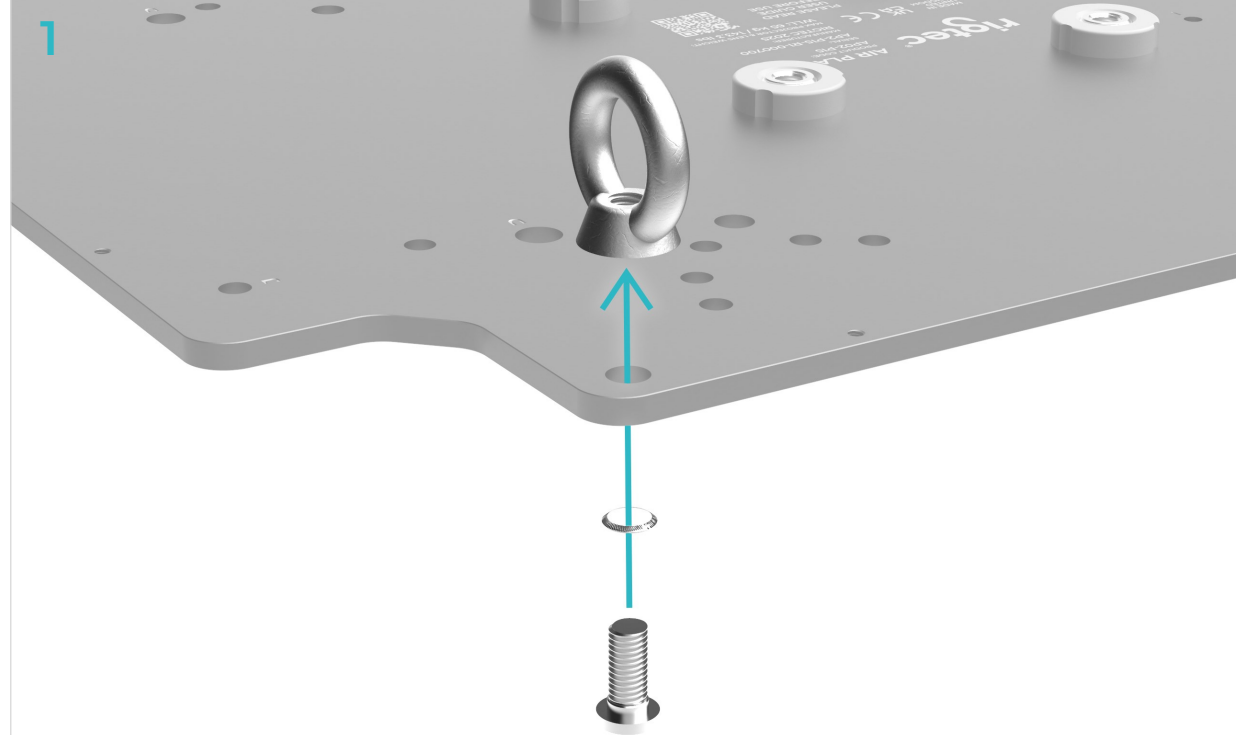



SPECIFICATIONS

Part Number: AP02-P15

Description: Air Plate P-15

Air Plate Weight: 2.8 KG / 6.17 lbs

Dimensions: 480mm (18.90") x 376mm (14.80") x 13mm (0.51")

WLL: 73KG / 160.9 lbs



DIMENSIONS

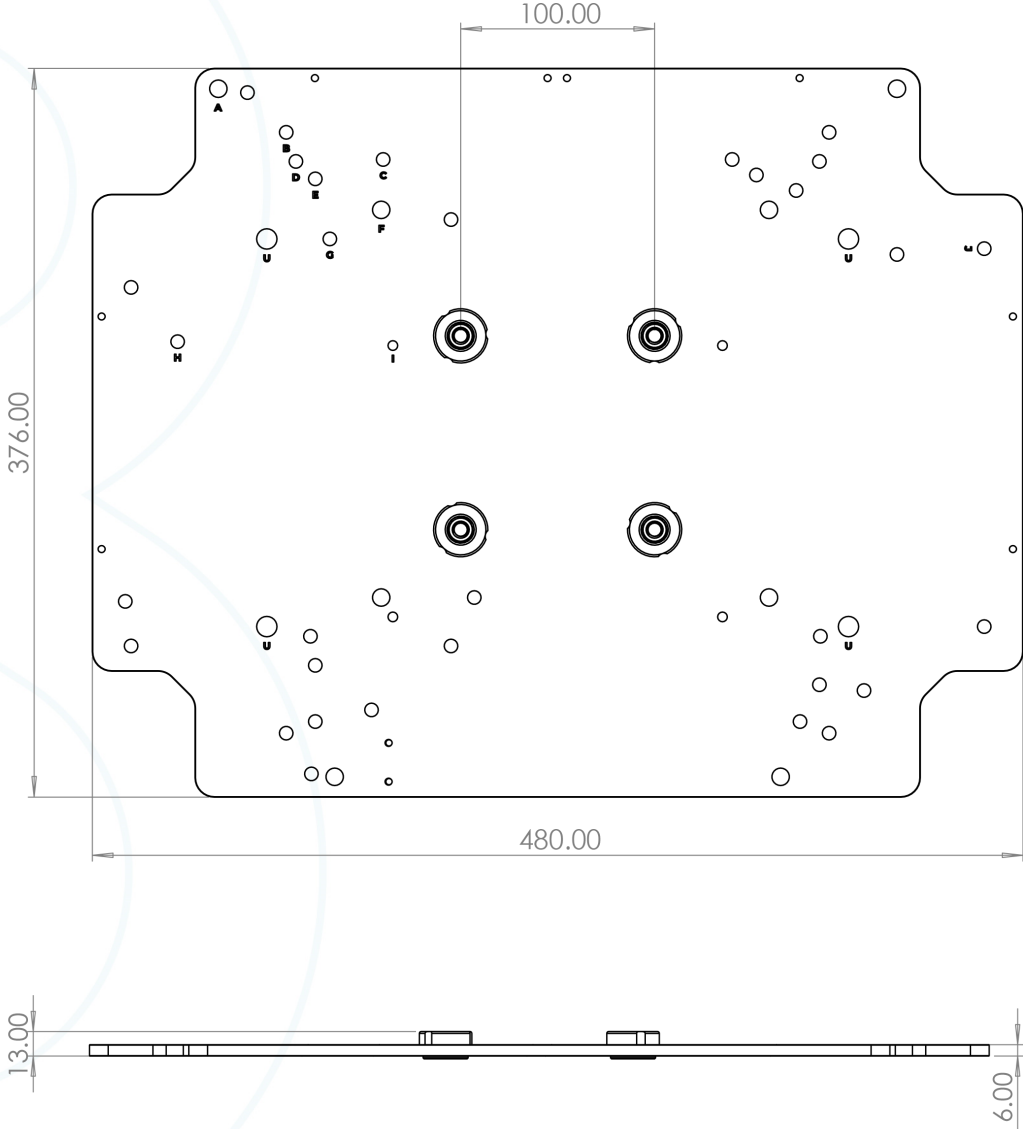



CE DECLARATION OF CONFORMITY



Manufacturer:

Rigtec Ltd
Unit B1 Holly Farm Business Park
Kenilworth
CV8 1NP
+44 (0) 1926 290 418
www.rigtec.com

Description of lifting accessory: Air Plate AP02-P15 Rigging Plate for Projector
Part Number: AP02-P15

Is in accordance with the following Directive:

Machinery Directive 2006/42/EC

Harmonised Standards:

EN ISO 12100:2010

Safety of machinery. General principles for design. Risk assessment and risk reduction

I hereby declare that the equipment named above has been designed to comply with the relevant sections of the above referenced specifications. The unit complies with all applicable essential requirements of the EC directives.

Signed:

Matthew Boyse - Authorised Representative
Rigtec Ltd
26/11/2025

Registered Address: Unit B1 Holly Farm Business Park, Honiley, Kenilworth, Warwickshire, CV8 1NP

Registration Number: 08702138



UKCA DECLARATION OF CONFORMITY



Manufacturer:

Rigtec Ltd
Unit B1 Holly Farm Business Park
Kenilworth
CV8 1NP
+44 (0) 1926 290 418
www.rigtec.com

Description of lifting accessory: Air Plate AP02-P15 Rigging Plate for Projector
Part Number: AP02-P15

Is in accordance with the following Directive:

Supply of Machinery [Safety] Regulations 2008 and Supply of Machinery [Safety] Regulations [A] 2011

Harmonised Standards:

EN ISO 12100:2010

Safety of machinery. General principles for design. Risk assessment and risk reduction

I hereby declare that the equipment named above has been designed to comply with the relevant sections of the above referenced specifications. The unit complies with all applicable essential requirements of the UKCA directives.

Signed:

Matthew Boyse - Authorised Representative
Rigtec Ltd
26/11/2025

Registered Address: Unit B1 Holly Farm Business Park, Honiley, Kenilworth, Warwickshire, CV8 1NP

Registration Number: 08702138